

griptech

HYDRAULIC WEIGHING SYSTEM | TC3000-RS



Attachments

Weighing systems

Camera systems

Features:

- ▶ Highest weighing precision $\pm 0.2\%$ **legal for trade**
- ▶ Most accurate system in legal for trade version
- ▶ SOLAS compliant method 1
- ▶ Rock-solid system with the best accuracy
- ▶ Protected against overvoltage

HYDRAULIC WEIGHING SYSTEM | TC3000-RS

Weighing accuracy $\pm 0.2\%$ of the load capacity of the reachstacker

For the loading of sea containers on ships, the weighing of sea containers is prescribed by the SOLAS directive. The highly accurate TC3000-RS weighing system weighs containers (method 1) with a deviation of approx. 500 kg. The system is integrated into the vehicle's hydraulic circuit and is therefore insensitive to impact forces. The angle of the boom is measured and the condition of the mast is ensured by a sensor. The system thus achieves the best accuracy in the world.

Features:

- Highest weighing precision $\pm 0.2\%$ **legal for trade**
- Most accurate system in legal for trade version
 - 50 kg steps up to 25,000 kg
 - 100 kg steps up to 50,000 kg
- Rock-solid system with the best accuracy
- SOLAS compliant method 1
- Indicator TC
- Protected against overvoltage

Options:

- Display unit with stainless steel housing
- ATEX version
- Printer and data transfer (e.g. via SmartBox or Griptech Connect)

Technical data:

- Protection class indicator TC: IP54
- Dimensions of TC indicator: W x H = 201 mm x 113 mm

Weighing procedure:

A. The highest accuracy is achieved when the container is lifted and then lowered after being picked up. This is also how the system is operated with calibrated systems. Weighing can be started when the container is lowered and begins fully automatically at a defined height. After approx. 8-10 seconds, the weight is shown on the display and stored until the next weighing.

B. The highest speed is achieved if we set the weighing procedure in one direction. However, the system becomes less accurate, which is still sufficient in many cases. It cannot be weighed in a legal for trade manner. However, the automatic weighing system can still be used.

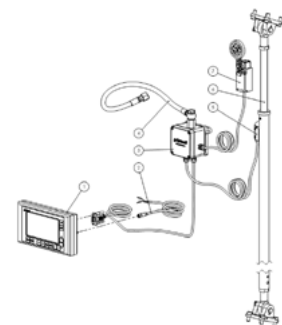
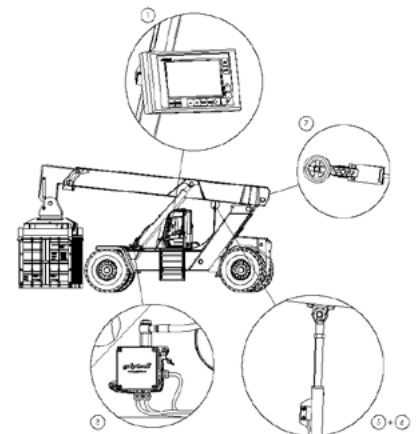

Hydraulic weighing system TC3000-RS incl. indicator TC				
Series	Load capacity of the forklift truck	Legal for trade version		
		up to 25,000 kg	up to 50,000 kg	up to 100,000 kg
TC3000-RS	up to 100,000 kg	50 kg	100 kg	200 kg