

griptech

HYDRAULIC WEIGHING SYSTEM | TC3000



Features:

- ▶ Highest weighing accuracy $\pm 0.1\%$ **legal for trade**
- ▶ Load center independent
- ▶ Rock-solid weighing system even for rough applications
- ▶ For vehicles with load capacities from 10,000 kg
- ▶ Automatic mast tilt compensation

Attachments

Weighing systems

Camera systems

HYDRAULIC WEIGHING SYSTEM | TC3000

Weighing accuracy $\pm 0.1\%$ of the truck capacity from 10,000 kg

Very stable and high-quality weighing system, whereby the weighing principle based on DMD (Dynamic Weight Determination Software) in combination with the TC display unit guarantees the best weighing result and the weighing data is displayed in full. This system has no effect on the load capacity of the vehicle, is independent of load center of gravity shifts and can also be used in combination with attachments. The system is installed protected in the vehicle, is insensitive to overloads and impact forces and is suitable for rough and intensive use.

Features:

- › Highest weighing accuracy $\pm 0.1\%$ legal for trade
- › Load center independent
- › For vehicles with load capacities from 10,000 kg
- › Rock-solid weighing system even for rough applications
- › Protected installation
- › Standard for vehicles without free lift
- › Automatic mast tilt compensation
- › Indicator TC
- › Protected against overvoltage
- › Everything from a single source, hardware and software developed in-house at Griptech
- › Wide range of models - the right system for every application

Options:

- › Display unit with stainless steel housing
- › ATEX version
- › Printer and data transfer (e.g. via SmartBox or Griptech Connect)

Technical data:

- › Supply voltage: 12 - 80 volts (legal for trade version 24 volts)
- › Working pressure: max. 400 bar
- › Protection class indicator TC: IP54
- › Dimensions of TC indicator: W x H = 201 mm x 113 mm

Weighing procedure:

The weighing process is initiated at the touch of a button. The load is raised and lowered while the optimum speed is monitored to display the weight within 8-10 seconds. The weight remains stored in the display until the next weighing. Deviations due to the mast tilt and a shift in the load's center of gravity are automatically compensated for without operator intervention.

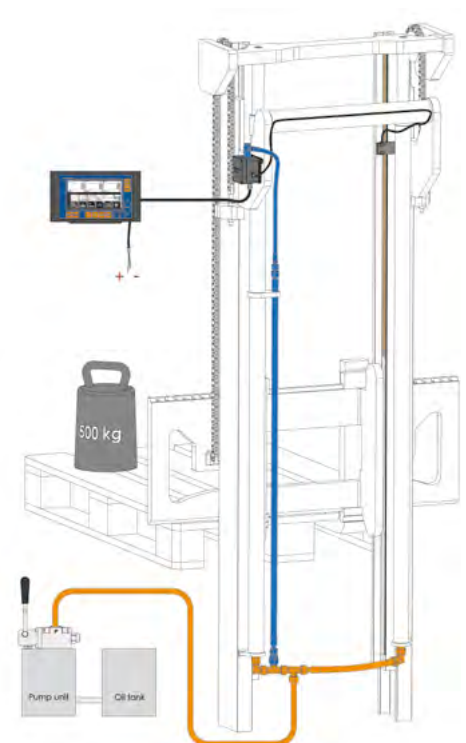

Hydraulic weighing system TC3000 incl. indicator TC					
Series	Load capacity of the forklift truck	Display steps in kg at nominal load capacity of the forklift truck			
		from 10,000 kg	up to 20,000 kg	up to 50,000 kg	up to 100,000 kg
For vehicles with standard mast					
TC3000	up to 100,000 kg	10 kg	20 kg	50 kg	100 kg