

griptech

ELECTRIC HIGH LIFT PALLET TRUCK | ST6



Attachments

Weighing systems

Camera systems

Features:

- ▶ Installation of 6 (calibratable) load cells
- ▶ Total height of the wheel arms increases by approx. 6 mm
- ▶ The modification by Griptech is always based on the original lift carriage
- ▶ Legal for trade version including class III certificate
- ▶ All welding work certified to ISO 3834-2

ELECTRIC HIGH LIFT PALLET TRUCK | ST6

Accuracy $\pm 0.1\%$ of the applied load

Almost all standard electric high lift pallet trucks in pedestrian version or with stand-on platform can be equipped with an integrated weighing system. The vehicles must be delivered to our factory for conversion. The load cells are integrated into the wheel arms and a weighing shoe is mounted.

The electric high lift pallet trucks can also be equipped with a hydraulic weighing system.

Features:

- › Weighing in high lift with 6 (Calibratable) load cells
- › Total height of the wheel arms increases by approx. 6 mm (legal for trade electric high lift pallet truck approx. 8 mm)
- › Wheel arm width increases by approx. 10 mm on both sides
- › The load protrudes approx. 50 mm further (lost load center)
- › Signal transfer via mast cable in the mast to the indicator
- › All welding work certified to ISO 3834-2
- › Legal for trade version including class III certificate
- › Extended load arms (from 1,600 mm with 8 load cells)
- › The modification by Griptech is always based on the original lift carriage, with all wear parts (mast bearings, chain anchors, load wheels, etc.) remaining in their original condition

Options:

- › Printer and data transmission (e.g. via SmartBox or Griptech Connect)
- › Indicator with numeric keypad and special functions (R420)
- › RS 232 interface incl. connection cable and Sub-D connector
- › Version with stainless steel shoes, cold storage version

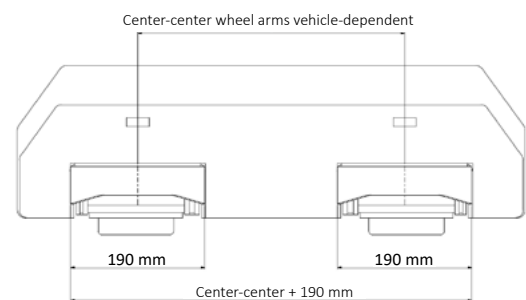

Electric high lift pallet truck ST6 (load capacity according to base model)

Series	Display arrangement
Standard electric high lift pallet truck (Indicator R320)	
ST6 up to 2000 kg	Dual range: 0.5 kg up to 500 kg, 1 kg up to 2,000 kg
Legal for trade according to class III (Indicator R320)	
ST6-E 1000 parts	1 kg up to 1,000 kg or 2 kg up to 2,000 kg
ST6-E 1500 parts	1 kg up to 1,500 kg
ST6-E 2000 parts	1 kg up to 2,000 kg

