

griptech

ELECTRIC LOW LIFT PALLET TRUCK | EP6

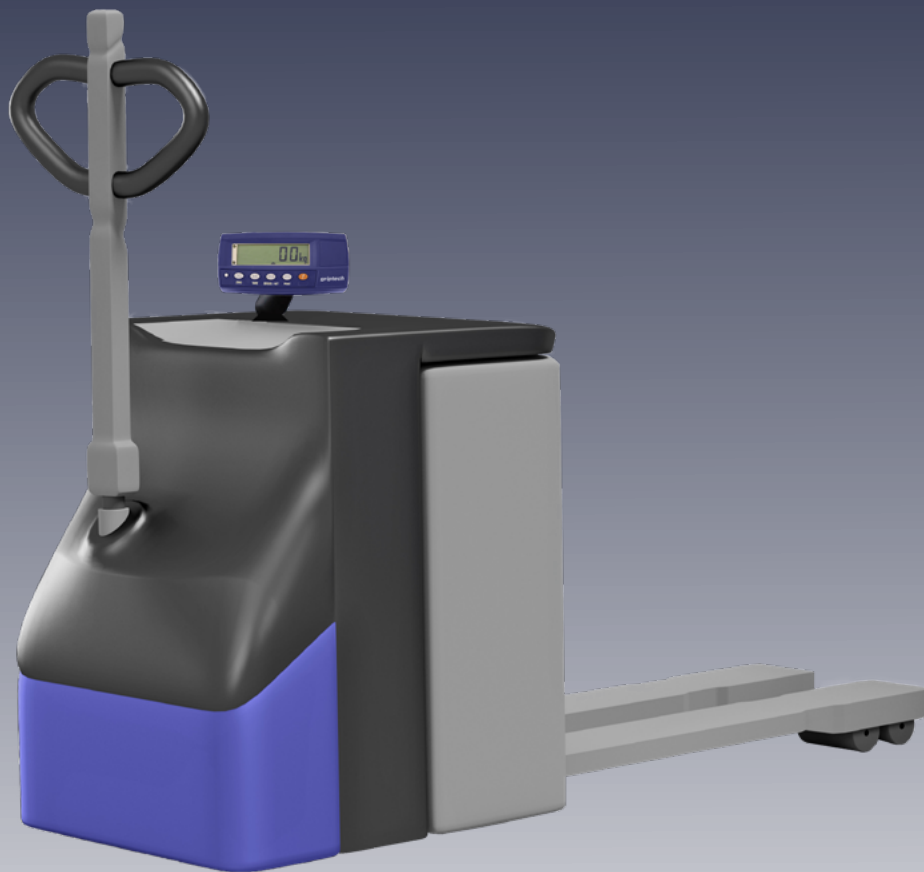

Features:

- ▶ Tapered fork tip for easier pallet entry
- ▶ HARDOX wear protection under the fork tip
- ▶ Optimally chamfered fork tip
- ▶ Three load cells in a row for optimal weighing results
- ▶ Legal-for-trade version according to Class III

Attachments

Weighing systems

Camera systems

ELECTRIC LOW LIFT PALLET TRUCK | EP6

Accuracy $\pm 0.1\%$ of the applied load

Almost all standard electric low lift pallet trucks in pedestrian version or with stand-on platform can be equipped with an integrated weighing system. The vehicles must be delivered to our factory for conversion.

The electric low lift pallet trucks can also be equipped with a hydraulic weighing system.

Features:

- › Installation of 6 (legal for trade) load cells in the wheel arms
- › The lowered height of the load arms generally remains unchanged; tolerances correspond to those of the base vehicle
- › Wheel arm construction replaced by Griptech
- › HARDOX wear protection under the fork tip
- › Optimally beveled fork tip
- › Heavy-duty construction especially for holding load cells
- › All welding work certified to ISO 3834-2
- › Legal for trade version including class III certificate
- › Extended wheel arms (from 1,600 mm with 8 load cells)

Options:

- › Printer and data transmission (e.g., via SmartBox or Griptech Connect)
- › Indicator with numeric keypad and special functions (R420)
- › RS 232 interface incl. connection cable and Sub-D connector
- › Version with stainless steel shoes, cold storage version
- › EP8 series with 8 load cells for extended load arms (from 1,600 mm)

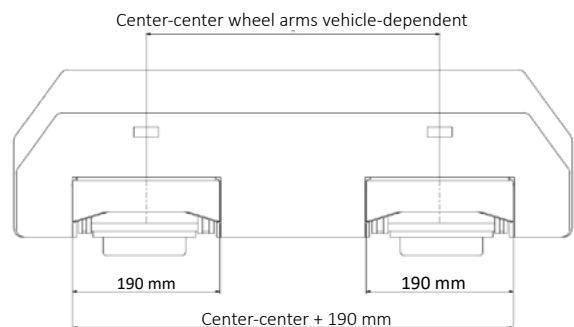
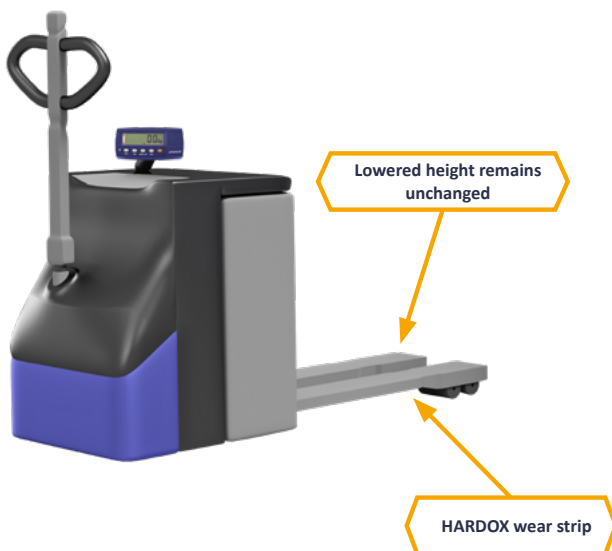

Electric low lift pallet truck EP6 (load capacity according to base model, standard wheel arm length 1150 mm)

Series	Display arrangement
Standard electric low lift pallet truck (Indicator R320)	
EP6 up to 2000 kg	Dual range: 0.5 kg up to 500 kg, 1 kg up to 2,000 kg
EP6 up to 2500 kg	2 kg steps
Legal for trade according to class III (Indicator R320)	
EP6-E 1000 parts	1 kg up to 1,000 kg or 2 kg up to 2,000 kg
EP6-E 1500 parts	1 kg up to 1,500 kg or 2 kg up to 3,000 kg
EP6-E 2000 parts	1 kg up to 2,000 kg
EP6-E 3000 parts	0.5 kg up to 1,500 kg

