

# ***griptech***

## HYDRAULIC WEIGHING SYSTEM | TC1000-D



### Features:

- ▶ Weighing accuracy  $\pm 0.5\%$  of the vehicle's rated capacity
- ▶ High dosing accuracy
- ▶ High level of connectivity (SmartBox, Griptech Connect)
- ▶ Compatible with all attachments
- ▶ Can be combined with a large display

Attachments

Weighing systems

Camera systems

# HYDRAULIC WEIGHING SYSTEM | TC1000-D

Accuracy  $\pm 0.5\%$  of the truck capacity

This hydraulic weighing system is used for dosing where weighing systems based on load cells are not possible or are too sensitive (large forklift trucks). The TC1000-D is integrated into the hydraulic system of the forklift truck via a sensor block without any exposed components on the mast or fork carriage, making the system maintenance-free even in the harshest environments. This system is regularly used in the steel industry or for filling or emptying.

## Features :

- › R320 indicator
- › Accuracy  $\pm 0.5\%$  of the truck capacity
- › High dosing accuracy
- › High level of connectivity (SmartBox, Griptech Connect)
- › Can be combined with a large display
- › Components are vibration- and shock-resistant
- › Protected against overvoltage

## Options:

- › Display unit with stainless steel housing
- › Printer and data transmission (e.g., via SmartBox or Griptech Connect)

## Technical Data:

- › Supply voltage: 12 – 24 Volts
- › R320 indicator protection class: IP65
- › R320 indicator dimensions (W × H): 166 mm × 77 mm

## Weighing procedure:

The weighing process is initiated at the touch of a button. The valve is activated during the entire weighing process and lowers evenly via the hydraulic block. With a measuring time of 1 minute, the load is lowered 15-20 cm.

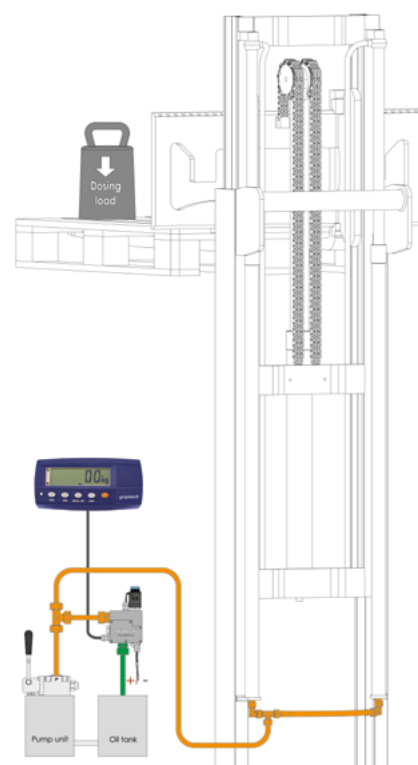

## Hydraulic weighing system TC1000-D incl. indicator R320

Series	Load capacity of the forklift truck	Display steps in kg at nominal load capacity of the forklift truck					
		up to 2,500 kg	up to 5,000 kg	up to 7,500 kg	up to 10,000 kg	up to 20,000 kg	up to 50,000 kg
TC1000-D MTU 15	bis 10.000 kg	2 kg	5 kg	10 kg	20 kg	-	-
TC1000-D MTU 30	bis 50.000 kg	-	-	-	-	50 kg	100 kg