

griptech

BOX ROTATOR | RM 190°

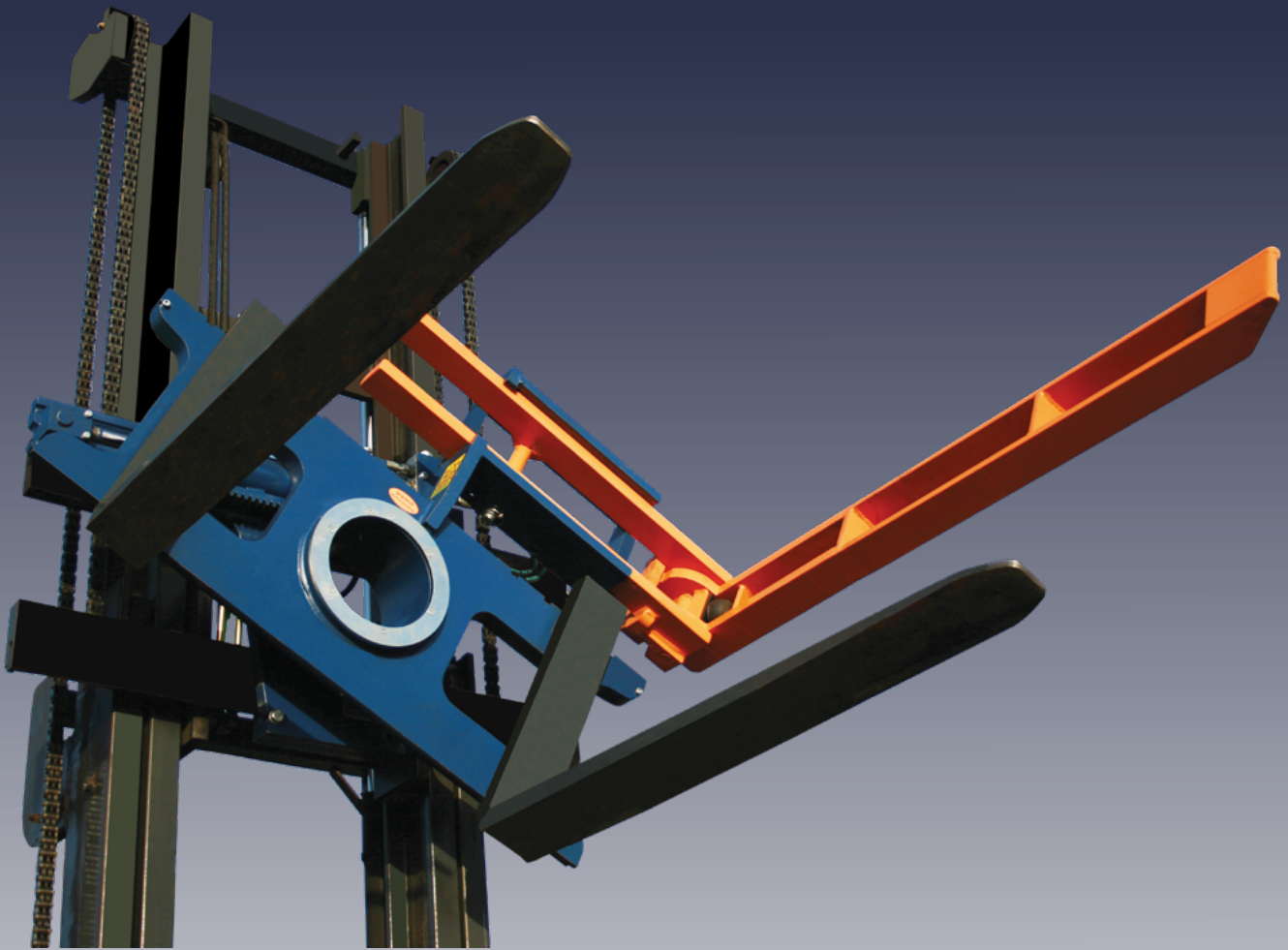

Attachments

Weighing systems

Camera systems

Features:

- ▶ Good visibility (patent protected)
- ▶ Reduced weight and lost load center
- ▶ Manual adjustment for crates up to 1600 mm wide
- ▶ Rotation range 10° more than usual

BOX ROTATOR | RM 190°

Rotatable 190° in one direction

Griptech box rotators are suitable for emptying boxes and containers in agriculture and for light industrial applications. The crates, which are closed at the bottom, are secured against slipping with the side clear-view support arm. The RM series can be rotated counter-clockwise 190° as standard via a robust rack and pinion drive. A large plain bearing ensures optimum power transmission and a long service life.

Features:

- Good visibility (patent protected)
- Reduced weight and lost load center
- Robust folding arm with automatic fixing in open or closed position
- Manual adjustment for crates up to 1600 mm wide
- Rotation range 10° more than usual

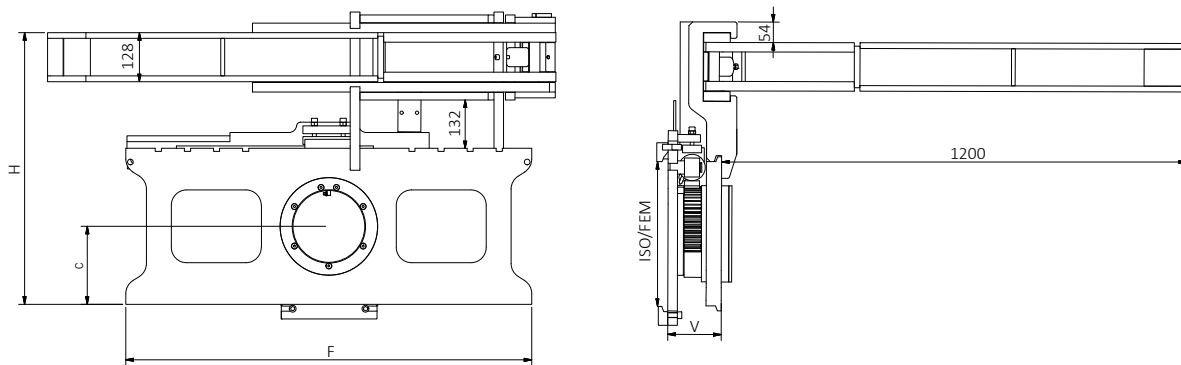
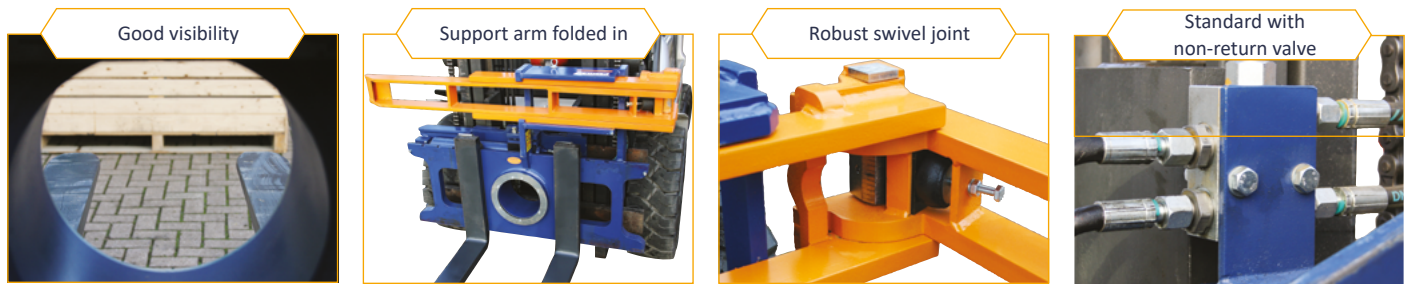

Box rotator 190° rotatable via rack and pinion drive (1 function without or 2 if with separate sideshift)

Series	Capacity in kg at 600 mm LC	ISO/ FEM	Width F mm	H mm	Minimal box height mm	C mm	V mm	Without sideshift		Separate sideshift		
								COG1/COG2 mm	Weight kg	V mm	COG1/COG2 mm	Weight kg
RM 12	1200	II	1060	675	750	205	141	85/130	200	158	95/120	235
RM 20	2000	II	1060	705	850	205	141	90/140	230	158	100/150	285
RM 30	3000	III	1100	810	950	255	156	100/145	300	173	130/185	365