

griptech

PALLET INVERTER | GVT

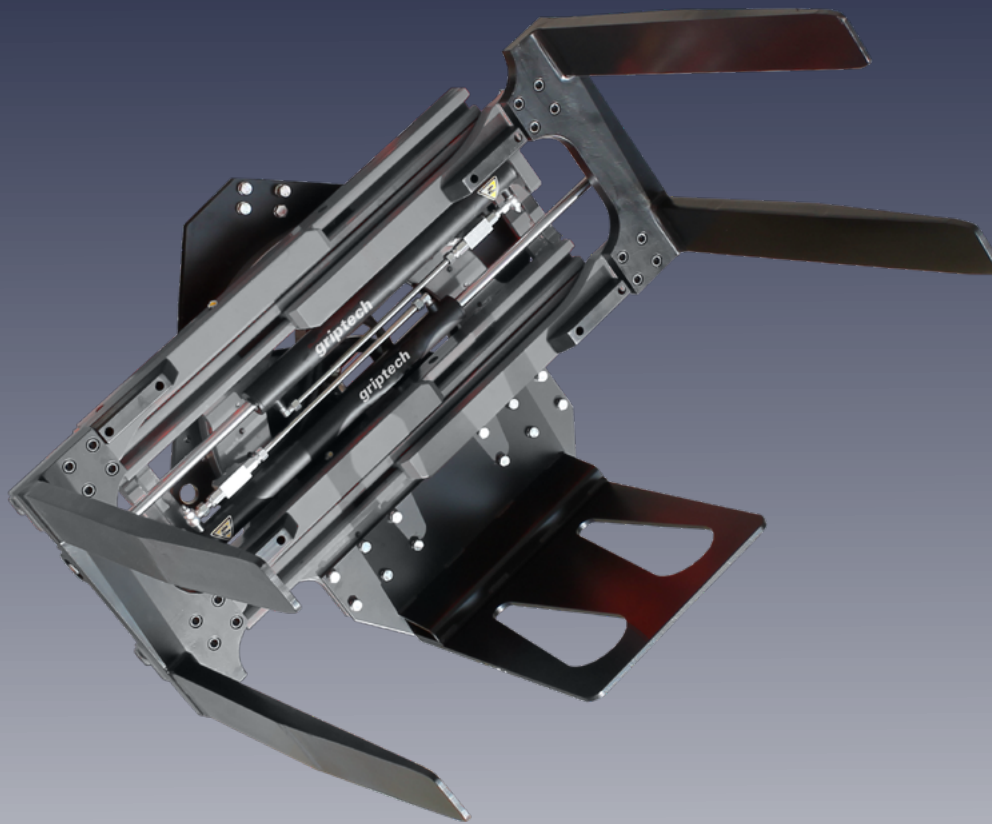

Features:

- ▶ Masterfully handles depalletizing and pallet changes
- ▶ Clamp body with robust, torsion-resistant arm profiles
- ▶ Compact front dimension and low own weight for optimal residual load capacity
- ▶ Welded guides allow for high clamp pressure
- ▶ Designed for handling Euro pallets

Attachments

Weighing systems

Camera systems

PALLET INVERTER | GVT

Perfectly handles depalletizing and/or pallet changes

The GVT pallet inverter masters depalletizing and pallet changing to perfection. Excellent visibility and the lateral support arm ensure an excellent handling process, reduced weight, lost load center and center of gravity. The clamp body with the robust, torsion-resistant arm profiles and the free view frame with welded guides enable high clamp pressure.

The GTR rotator enables a load to be rotated quickly and precisely. The design of the gear drive and gear rim offers a correspondingly long service life at high working speeds. The large viewing window provides the driver with the best possible view of the fork tips. The indirect drive guarantees high torque values and smooth, powerful rotation of the load.

Features:

- ▶ Perfectly handles depalletizing and pallet changes
- ▶ Clamp body with robust, torsion-resistant arm profiles
- ▶ Compact front dimension and low own weight for optimal residual load capacity
- ▶ Welded guides allow for high clamp pressure
- ▶ Designed for handling Euro pallets

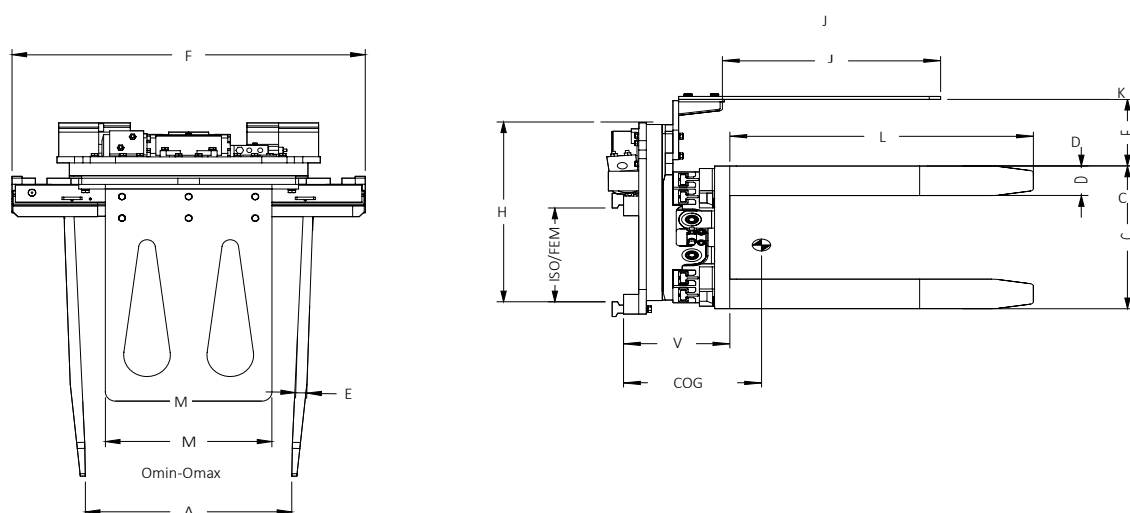

Pallet inverter fork length L = 1200 mm (2 functions)

Series	Load capacity in kg at 500 mm LC	ISO/ FEM	Width F mm	Omin-Omax mm	Cross section D-E	C mm	H mm	V mm	COG mm	Weight kg
GVT15E160C.120	1200	II	1060	440-1700	120-40	580	260	280	292	618
GVT15E470C.120			1360	550-2210	120-40	580	260	280	280	630
GVT20E470C.120			1900	1360	580-2240	120-40	580	260	280	280
GVT30E160E.120	2500	III	1060	440-1700	120-50	580	260	320	320	665
GVT30E470E.120			1360	540-2200	120-50	580	260	320	300	685
Version with extra large opening range										
GVTE20E160C.120	1900	II	1060	1125-1755	120-40	580	375	280	331	598
GVTE20E270C.120			1160	1325-2055	120-40	580	375	280	329	608