

griptech

ROTATOR | KIK 360°

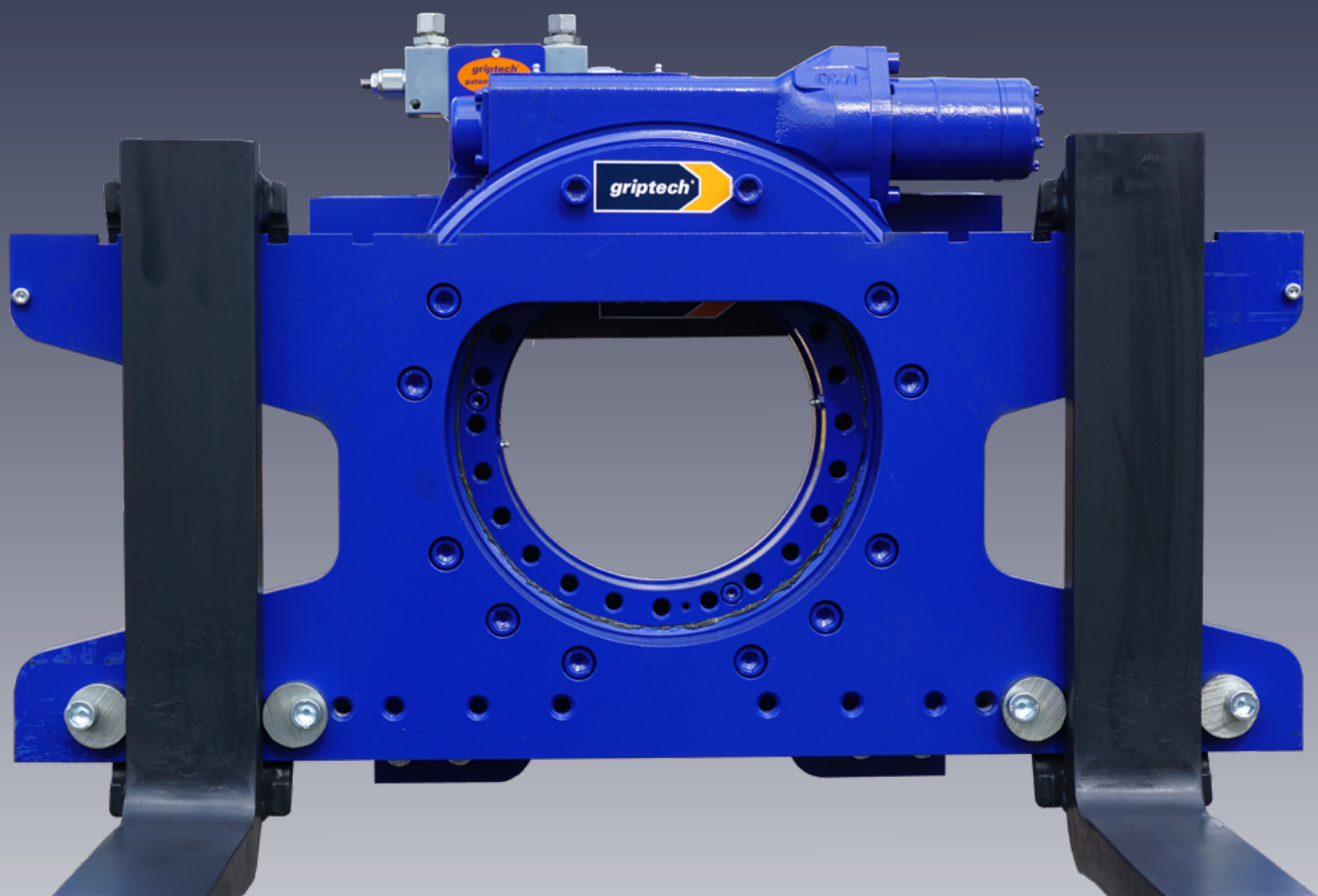

Attachments

Weighing systems

Camera systems

Features:

- ▶ Slewing ring with direct drive via a worm gear
- ▶ Suitable for emptying boxes and containers with entry pockets
- ▶ Great visibility
- ▶ Reduced weight and overhang
- ▶ Includes lateral fork locking mechanism

ROTATOR | KIK 360°

Continuously rotatable in both directions

High-quality rotators with a slewing ring with direct drive via a worm shaft, whereby several windings are always engaged. Suitable for emptying crates and containers with entry pockets for the forks. The devices offer very good visibility. Standard incl. non-return valve and a lateral fork locking mechanism for different fork widths and width positions. We recommend that you use forks with reinforced lower claws.

Load capacity up to 3,200 kg.

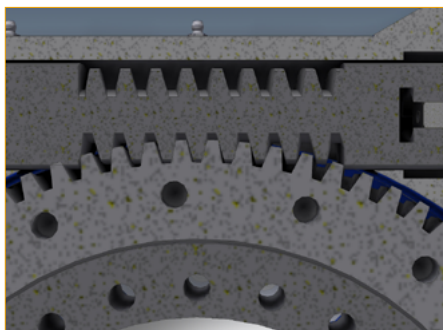

Direct drive with worm shaft

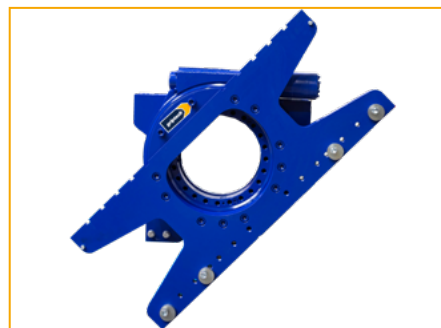

Including lateral fork locking mechanism

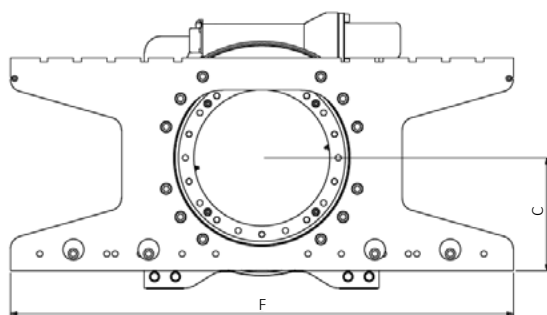

Rotator 360° direct drive via worm shaft (1 function without or 2 if with separate sideshift)

Series	Capacity in kg at 600 mm LC	ISO/ FEM	Width F mm	C mm	Omax mm	Oil volume per rotation L	Max. torque at 130 bar	Without sideshift			Separate sideshift		
								V mm	COG mm	Weight kg	V mm	COG mm	Weight kg
KIK 25-360	2500	II	1000	205	800	6,8	6900 Nm	147	74	170	162	70	220
KIK 32-360	3200	III	1200	254	980	10,4	8500 Nm	167	86	265	182	81	325