

griptech

FOAM CLAMP | GPO-E

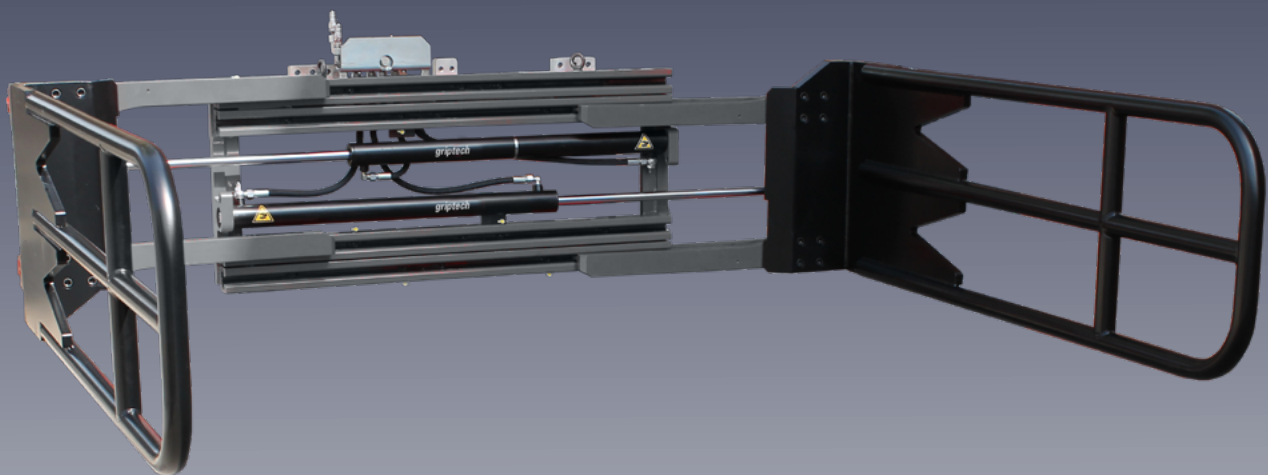

Attachments

Weighing systems

Camera systems

Features:

- ▶ With integrated side shift
- ▶ For transporting large-volume and lightweight loads
- ▶ Reduced weight, lost load center, and center of gravity
- ▶ Free view frame with welded guides
- ▶ Lightweight arm design for secure gripping and damage-free transport

FOAM CLAMP | GPO-E

For pallet-free transport of items such as rubber or foam blocks

The GPO-E foam clamp is designed for pallet-free handling of large-volume yet lightweight loads, such as rubber or foam blocks. The extremely lightweight arm design ensures secure gripping and damage-free transport. The integrated side shift compensates for minor alignment inaccuracies. Excellent visibility is combined with reduced weight, lost load center, and center of gravity.

Features:

- › With integrated side shift
- › For transporting large-volume and lightweight loads
- › Reduced weight, lost load center, and center of gravity
- › Free view frame with welded guides
- › Lightweight arm design for secure gripping and damage-free transport

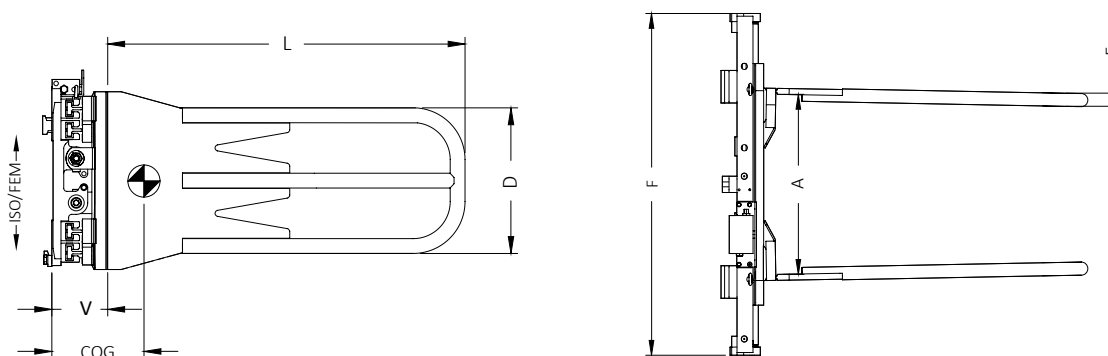

Foam clamp (2 functions, with integrated sideshift)

Series	Load capacity in kg at LC in mm	ISO/ FEM	Width F mm	A mm	L-D mm	V mm	COG mm	Weight kg
GPO15E375C.128	800/800	II	1260	665-2225	1280-475	178	197	389
GPO15E375C.150	800/800	II	1260	665-2225	1500-475	178	236	410
GPO15E375C.200	800/800	II	1260	665-2225	2000-475	178	291	424