

griptech

PAPER ROLL CLAMP | GPD-200



Features:

- ▶ Load capacity from 2,300 kg to 3,400 kg
- ▶ Equipped with a movable long arm and a fixed short arm
- ▶ Ideal for handling single rolls
- ▶ Particularly slim and robust arm design
- ▶ 360° continuous rotation in both directions

Attachments

Weighing systems

Camera systems

PAPER ROLL CLAMP | GPD-200

With a fixed short arm and a single-piece long arm

The GDP-200 series roll clamp features a movable long arm and a fixed short arm. Thanks to the long single-piece arm, it is ideal for handling single rolls. The particularly slim and robust arm design facilitates the handling process, increases throughput efficiency, and minimizes the risk of collision damage.

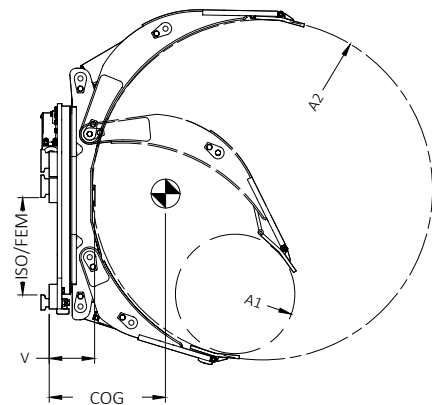
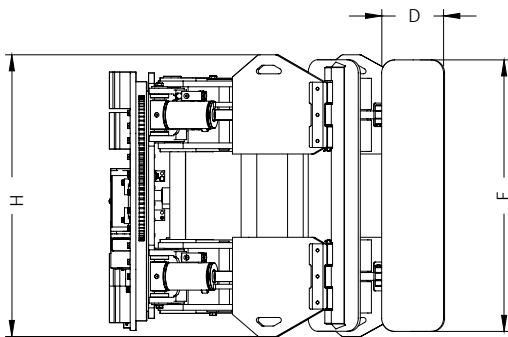

Paper roll clamp 360° rotatable (2 functions)								
Series	Load capacity in kg at LC in mm	ISO/ FEM	A1-A2 mm	Cross section D-E mm	H mm	V mm	COG mm	Weight kg
GPD20E213C	2300/650	II	640-1300	240-840	900	205	274	628
GPD20E213E		III	640-1300			250	319	642
GPD20E216C	2000/800	II	640-1600	240-840	900	205	305	729
GPD20E216E		III	640-1800			205	340	812
GPD20E218C	1800/900	II	600-1800	240-840	900	205	340	812
GPD20E218E		III	600-1800			250	390	824
GPD30E213E	3300/650	III	700-1300	240-1040	1080	200	277	979
GPD30E213G		IV	700-1300			200	277	984
GPD30E216E	3000/800	III	700-1600	240-1040	1080	200	310	1050
GPD30E216G		IV	700-1600			200	310	1050
GPD40E213E	4500/650	III	700-1300	240-1040	1080	245	301	1155
GPD40E213G		IV	700-1300			245	301	1155
GPD40E216E	4000/800	III	700-1600	240-1040	1080	245	316	1206
GPD40E216G		IV	700-1600			245	316	1206
GPD40E218E	3400/900	III	700-1800	240-1040	1080	245	345	1295
GPD40E218G		IV	700-1800			245	345	1295